

MINIMUM CLEARANCE REQUIREMENTS

WALL MOUNTED

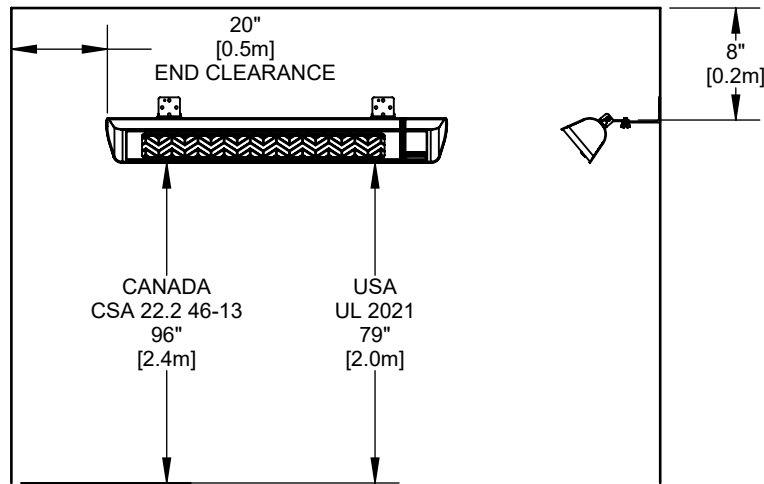

6' FRONTAL CLEARANCE TO FLAMMABLE OBJECTS REQUIRED

CEILING MOUNTED

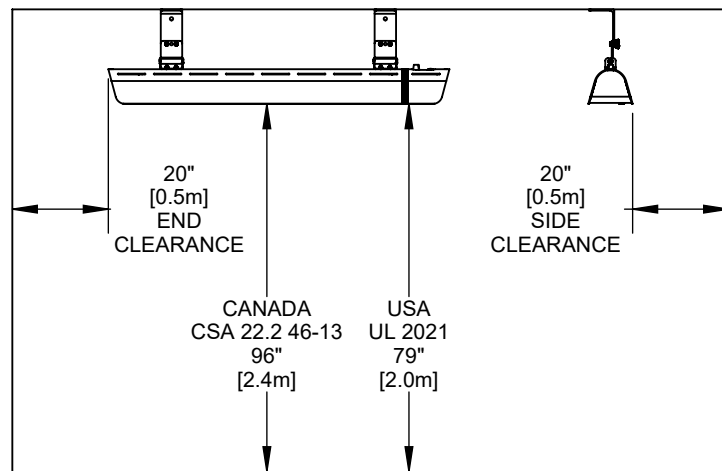

MEDIUM WAVE INFRARED HEATERS FOR:
 INDOOR USE - RESIDENTIAL (1500W ONLY*), COMMERCIAL AND INDUSTRIAL
 OUTDOOR USE - RESIDENTIAL, COMMERCIAL AND INDUSTRIAL
 FOR USE IN NON-HAZARDOUS AREAS ONLY
 HEATERS INCLUDE IP 65 RATING AND ARE APPROVED FOR OUTDOOR USE
 GLASS MODELS NOT RECOMMENDED IN WINDY OR EXPOSED ENVIRONMENTS

INCLUDED FEATURES

- BLUETOOTH CONTROLS
- WALL MOUNT BRACKETS
- BRACKET HARDWARE (EXCLUDES ANCHOR BOLTS)
- REMOTE CONTROL
- 8' CABLE WITH NEMA 6-15 PLUG

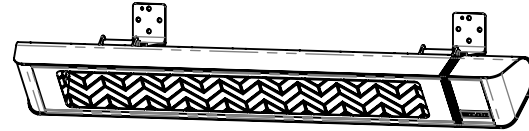

OPTIONAL ITEMS

- OPTIONAL SUSPENSION POLE PACKAGE*
 *SOLD SEPARATELY

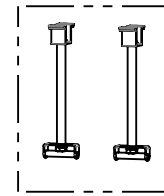

AVAILABLE MODELS:

3000W GLASS FASCIA
ADGLASS30240*



3000W GRILLE FASCIA:
AD30240*

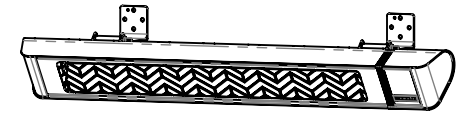

WALL MOUNTED

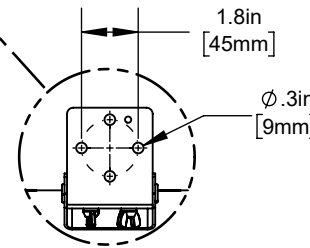
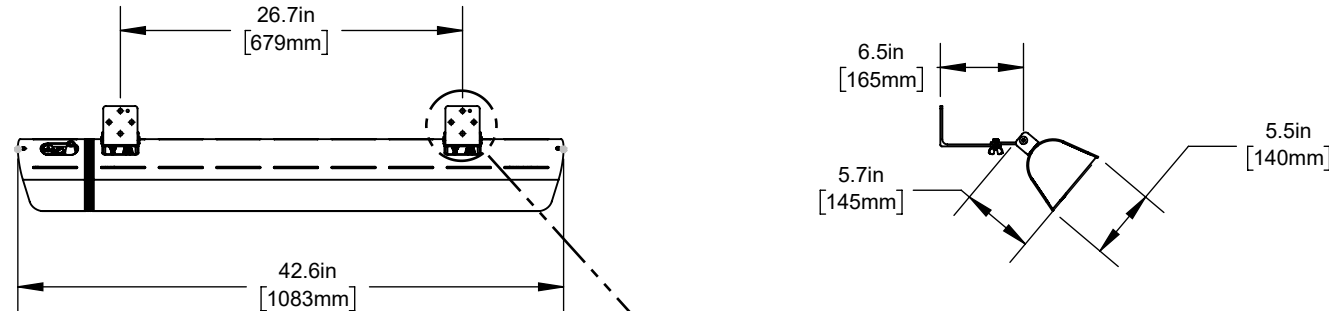

CEILING SUSPENDED

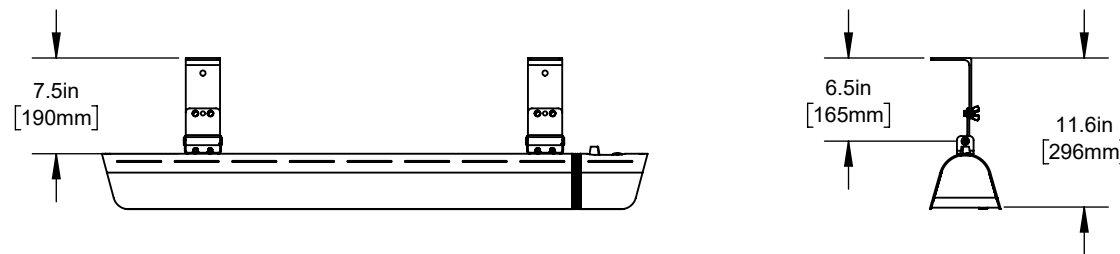

SUITABLE MOUNTING CONFIGURATIONS

1. WALL MOUNTED
 2. CEILING MOUNTED
 3. CEILING SUSPENDED*
- *OPTIONAL SUSPENSION BRACKET PACKAGE SOLD SEPARATELY

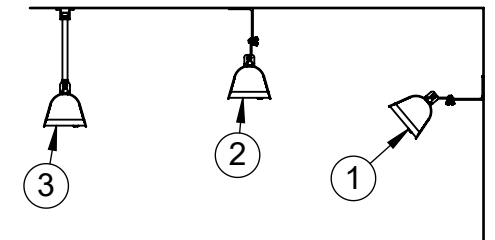

HEATER COVERAGE PATTERN

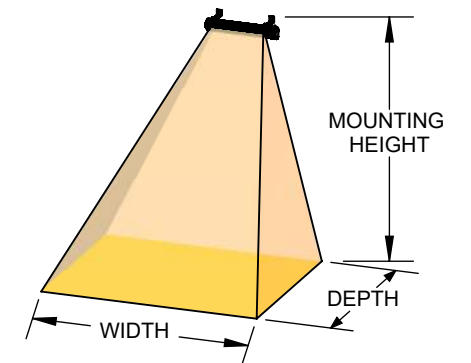

MODEL	MOUNTING HEIGHT	WIDTH	DEPTH	HEAT ZONE	AVERAGE HEAT DENSITY
AD30240	8' (2.4m)	12' (3.6m)	7' (2.1m)	84ft² (7.8m²)	34 W / ft²
ADGLASS30240	8' (2.4m)	10' (3.1m)	6' (1.8m)	60ft² (5.6m²)	25 W / ft²

*HEAT DENSITY IS REDUCED BY 25% WHEN DE-RATED TO 208V

**HEATER SPECIFICATIONS

DESCRIPTION	ITEM/ SKU	WEIGHT (LBS/KG)	240V				208V			
			WATTS	BTU's	VOLTS	AMPS	WATTS	BTU's	VOLTS	AMPS
AURA DECOR GLASS- 3000W / 240V	ADGLASS30240*	13 / 5.9	3000	10200	240	12.5	2250	7675	208	10.8
AURA DECOR GRILLE - 3000W / 240V	AD30240*	13 / 5.9	3000	10200	240	12.5	2250	7675	208	10.8



A1	2022-12-12
REVISION	DATE: YYYY-MM-DD



MODEL **ADGLASS30240**
AD30240

SHEET NO. 1 OF 2

SHEET SCALE 1:15 SHEET SIZE 11X17

**SKU NOTES: * SEE CATALOG FOR AVAILABLE COLORS. ALL HEATERS COME WITH STANDARD ONBOARD BLUETOOTH, 6.5" BRACKETS, 6-STEP REMOTE CONTROL | ** SPECIFICATIONS SUBJECT TO CHANGE WITHOUT NOTICE

NOTICE: THIS DOCUMENT IS NOT A SUBSTITUTE FOR APPROVED MANUAL. Failure to follow instruction manual may cause fire, electric shock or injury to persons. AURA TM is a registered trademark of Inforesight Consumer Products. Customer, contractor specifier and installer understands that some or all products provided by Inforesight Consumer Products Inc. may not be available for purchase or installation in certain jurisdictions or geographical areas. Inforesight Consumer Products Inc. reserves the right, in its sole discretion, to exclude or otherwise limit the provision of any product to a person or entity residing in any jurisdiction or geographical area outside of Canada. Inforesight Consumer Products Inc. provides general product installation guidelines and procedures and Customer, contractor, specifier and installer understands that Customer, contractor, specifier and installer is solely and exclusively responsible for installation of the product and ascertaining all applicable local municipal, provincial, state, and federal NEC (National Electrical Code) rules, by-law, ordinances and guidelines applicable to the installation of any Inforesight Consumer Products Inc. products. Customer contractor, specifier and installer must strictly adhere to and be compliant with the local rules, laws, ordinances and legal requirements for the safe installation and use of any Inforesight Consumer Products Inc. products. Instruction manuals are included with the product packaging and copies of our instruction manuals are available upon request. Under no circumstances shall Inforesight Consumer Products Inc. or its affiliated entities, employees, agents, shareholders, officers or directors be liable to Customer or any third party for any product installations and Customer, contractor, specifier and installer releases Inforesight Consumer Products Inc. from any and all losses, death, personal injury, property damage, other damages, rights, claims, demands and actions of any kind arising from the Customer's installation and use of the product, whether the installation was or was not in accord with the provided instruction manual and/or in compliance with applicable local laws. Solaira products are to be installed by licensed technicians per instruction manuals and to all provincial/state and national (N.E.C.) code requirements; specifications subject to change without notice.